



SILNIKI INDUKCYJNE DO NAPĘDU PIŁ TARCZOWYCH I OBRABIAREK DO DREWNA INDUCTION MOTORS FOR DRIVE OF THE CIRCULAR SAWS AND WOODWORKING MACHINES ELEKTROMOTOREN ZUM SÄGEN, BOHREN, FRÄSEN FÜR HOLZBEARBEITUNG

Dane techniczne:

- stopień ochrony IP54, IP55

Technical data:

- degree of protection IP54, IP55

Technische Daten:

- Schutzart IP54, IP55

Typ	Rodzaj pracy	Częstotliwość Hz	Moc kW KM	Napięcie V	Prąd A	Prędkość obrotowa min ⁻¹	Sprawność η%	Współczynnik mocy cosφ	Krotność prądu rozruchowego I _s /I _N	Krotność momentu rozruchowego M _s /M _N	$\frac{M_{max}}{M_N}$	Moment bezwładności kgm ²	Masa [kg]	Konden- sator pracy 450 V μF	Klasa izolacji
Frame size	Operating mode	Frequency Hz	Rated output kW HP	Voltage V	Rated current A	Rated speed min ⁻¹	Efficiency η%	Power factor cosφ	Starting current /rated current I _s /I _{FL}	Starting torque /rated torque T _s /T _{FL}	$\frac{T_{max}}{T_{FL}}$	Moment of inertia kgm ²	Weight [kg]	Running Capacitor 450 V μF	Insulating class
Typ	Betriebsart	Frequenz Hz	Nennleistung kW PS	Spannung V	Nennstrom A	Nenn- drehzahl min ⁻¹	Wirkungs- grad η%	Lei- stungs- factor cosφ	Anzugs- strom zu Nenn- strom I _s /I _N	Anzugs- moment zu Nenn- moment M _s /M _N	$\frac{M_{max}}{M_N}$	Trägheits- moment kgm ²	Gewicht [kg]	Betriebs- konden- sator 450 V μF	Isolierstoff- klasse

TRÓJFAZOWE SILNIKI INDUKCYJNE THREE-PHASE INDUCTION MOTORS DREHSTROMMOTOREN

SPg 63-2A	S1	50	0,75	1,0	400	1,8	2740	71	0,84	4,4	3,6	3,8	0,0012	12,5	—	F
	S6 40%	50	1,0	1,4	400	2,4	2720	70	0,86	3,5	2,6	2,8				
SPg 63-2AB	S1	50	1,1	1,5	400	2,5	2815	80	0,79	5,6	3,8	2,9	0,0014	15	—	F
	S6 40%	50	1,5	2,0	400	3,3	2780	77	0,85	4,5	2,8	2,0				
SPg 63-2B	S1	50	1,5	2,0	400	3,3	2800	79	0,82	6,0	3,9	3,6	0,0019	20	—	F
	S6 40%	50	2,0	2,7	400	4,2	2790	79,5	0,87	4,8	3,0	2,8				
SPg 75-2B	S1	50	3,5	4,7	400	7,1	2810	81	0,88	6,3	3,1	3,2	0,0040	26,7	—	F
	S6 40%	50	4,6	6,2	400	9,5	2730	78	0,90	4,8	2,3	2,4				
SPg 75-2D	S1	50	4,7	6,3	400	9,5	2845	82,5	0,87	7,1	3,3	3,5	0,0050	32,8	—	F
	S6 40%	50	6,0	8,0	400	11,9	2800	81	0,90	5,6	2,6	2,7				
SPg 75-2E	S1	50	5,2	7,1	400	10,5	2865	85	0,84	6,0	3,5	3,6	0,0055	36	—	F
	S6 40%	50	6,5	8,8	400	12,7	2840	84	0,88	4,8	2,7	2,8				

JEDNOFAZOWE SILNIKI INDUKCYJNE Z KONDENSATOREM PRACY SINGLE-PHASE INDUCTION MOTORS WITH THE PERMANENT CAPACITOR EINPHASENMOTOREN MIT BETRIEBSKONDENSATOR

SEPg 75-2A	S1	50	1,5	2,0	230	8,7	2820	76	0,99	4,4	0,5	2,1	0,0027	22,5	55	F
	S6 40%	50	1,9	2,5	230	11,9	2690	70	0,99	3,2	0,4	1,7				
SEPg 75-2B	S1	50	2,2	3,0	230	13,1	2740	74	0,99	4,0	0,45	2,3	0,0032	25	75	F
	S6 40%	50	2,4	3,2	230	15,1	2770	70	0,99	3,5	0,4	2,1				

SPg, SEPg - silniki w obudowie ze stopu Al.

SPg, SEPg - motors with frame of aluminium alloy.

SPg, SEPg - Motorgehäusen aus Al Legierung.

Standardowo silniki są znamionowane na pracę S1

The motor's nameplate bears data valid for duty S1

Die Motoren sind standardweise für S1 gekennzeichnet

– Wymiary montażowe i zewnętrzne patrz str. 16

– The mounting and overall dimensions. See! Page 16

– Die Anbau-und Außenmaße siehe Seite 16

WYMIARY MONTAŻOWE I ZEWNĘTRZNE DO KARTY Ta-52.2000

THE MOUNTING AND OVERALL DIMENSION CONC. THE CATALOGUE CARD NO Ta-52.2000

DIE ANBAU-UND AUSSENMASSE ZUR KARTE Ta-52.2000

WYMIARY MONTAŻOWE I ZEWNĘTRZNE

PRINCIPAL DIMENSIONS

ABMESSUNGEN

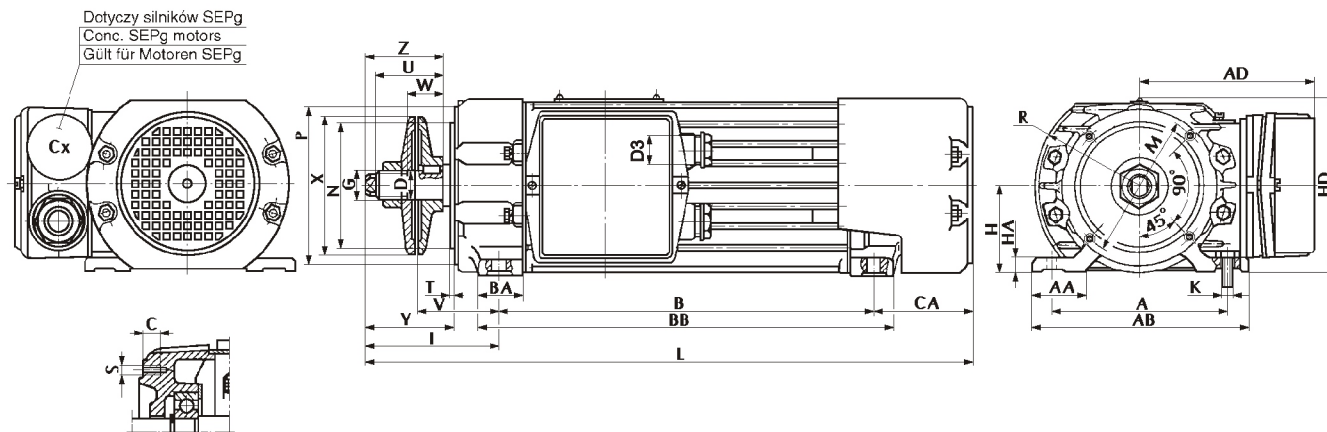

Typ Frame size Typ	Wymiary montażowe [mm] Mounting dimensions [mm] Einbaumasse [mm]														Wymiary zewnętrzne [mm] Overall dimensions [mm] Aussenmasse [mm]											Łożysko Bearing Kugellager					
	A	B	H	HA	K	M	N	V	D	C	S	G	X	D3	L	AA	AB	BB	CA	AD	HD	R	T	P	BA		Z	U	W	Y	I
SPg 63-2A	130±0,4	285 ^{+0,5} _{-0,7}	63 ^{+0,4} _{-0,5}	12	M10	105	90h8	64 ^{+0,8} _{-1,2}	20g6 22k6	12	M6	M20x2	98	M20	405	40	160	263	78,5	138	126	78	3	115	34,5	60	52	30	68	103	6306 2RS 6206 2RS
SPg 63-2AB															431			289													
SPg 63-2B															466			324													
SPg 75-2B SEPg 75-2A SEPg 75-2B	140±0,4	285 ^{+0,5} _{-0,7}	75 ^{+0,5} _{-0,5}	16	M10	120	105h8	73 ^{+0,8} _{-1,2}	30g6	12	M6	M27x2	118	M20	485,5	40	170	324	79,5	150	152	92	3	135	34,5	76	68	42	86	121	6307 2RS 6206 2RS
SPg 75-2E															550,5			389													
SPg 75-2D															550,5			389													

SPg, SEPg - silniki w obudowie ze stopu Al.

Silniki SPg, SEPg mogą być dostarczane z nabudowanym hamulcem prądu stałego (zasilanie prądem przemiennym o napięciu 400V) o momencie hamowania $M_H=3$ Nm dla silników SPg 63 i $M_H=4$ Nm dla silników SPg75 i SEPg 75.

SPg, SEPg - motors with frame of aluminium alloy.

Motors SPg, SEPg may be delivered with DC brakes (400V AC supply), braking torque $M_H=3$ Nm for SPg 63 motors and $M_H=4$ Nm for SPg75 and SEPg 75 motors.

SPg, SEPg - Motorgehäusen aus Al Legierung.

Motoren SPg, SEPg können mit Gleichstrombremse (400V Wechselstrom gespeist) geliefert werden; Bremsmoment für Motoren SPg63 beträgt $M_H=3$, für Motoren Spg75 und SEPg75 beträgt $M_H=4$ Nm.